

## MARITIME ENVIRONMENT PROTECTION SYSTEMS



Shredding | Volume Reduction | Sterilisation

### **MACS 130 M - Machine Autoclave Cutting Sterilisation**



The Ocean Clean MACS is a sophisticated heavy-duty shredder that will cut all kinds of waste: paper, plastic, cardboard, tins, glass, food waste and more.

After shredding waste is reduced in size (up to 80% volume reduction) and can be stored or disposed. During a vacuum drying process wet waste (e.g. food waste) will lose mass and volume.

Contaminated waste and food waste will be heat-treated for sterilization to not produce mold or rot and to allow for easy and uncooled storage.





## MACS 130 M

Contact Ocean Clean for original, reliable and genuine spare parts.

# FOR OCEAN'S SAKE



Robust, reliable and secure design combined with user-friendly on-screen controls and programs for different types of waste.

- Compact unit
- Robust design
- Powerful shredder
- Stainless steel
- On-screen controls
- Sensor controlled
- Long service life
- Made in Germany

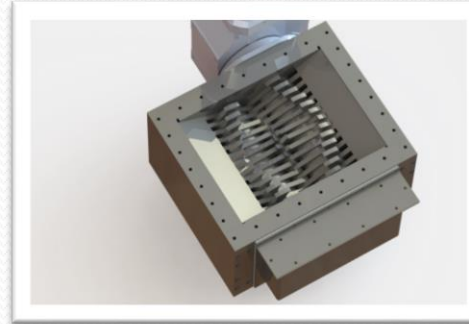

Powerful and sturdy long-life shredder with high accuracy to break-up hard and soft materials including glass and metal.



Replaces equipment such as: Glass crusher, bone crusher, bale press, tin compactor, PET crusher, and many more.  
Allows for secure and easy storage.



Ocean Clean - A Member of Kloska Group & Neuenhauser Group



Ocean Clean GmbH  
Zum Kühlhaus 5  
18069 Rostock  
Germany

Phone: +49 381 811 29 30  
Fax: +49 381 811 29 39  
E-Mail: [info@oceanclean.de](mailto:info@oceanclean.de)  
Web: [www.oceanclean.de](http://www.oceanclean.de)

# Ocean<sup>®</sup> Clean GmbH



## MACS 130 M

Contact Ocean Clean for original, reliable and genuine spare parts.

# FOR OCEAN'S SAKE

### Advantages

Intended for: Treatment of waste from kitchen, cabins and to sterilize infectious waste (hospital). Can shredder paper, cardboard, plastic foil, plastics, PET bottles, glass bottles, jars, tins, cans.

Operating principle: Waste is filled in feed hopper (size: 130 litres), then shredded and finally heat treated and dried via vacuum.

Efficiency: Dry waste is reduced in volume by up to 80%. Wet waste is dehydrated to lose up to 50% of its weight. Sterilisation process will kill 99,99% of germs and virus.

Powerful high-precision shredder, driven by two motors, to shred soft and hard dry and humid waste.

Available with stainless steel blades for highest durability.

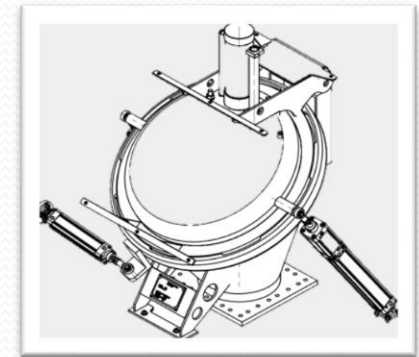

Feed hopper with 130l volume as part of the pressure vessel. Opens and closes automated. Pneumatic seals ensure safe operation.

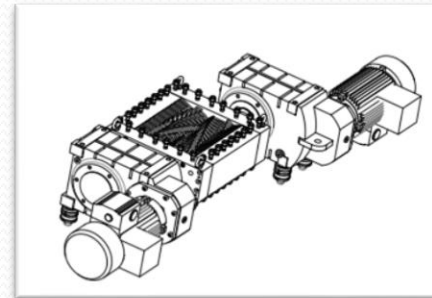

Ocean Clean - A Member of Kloska Group & Neuenhauser Group



Ocean Clean GmbH  
Zum Kühlhaus 5  
18069 Rostock  
Germany

Phone: +49 381 811 29 30  
Fax: +49 381 811 29 39  
E-Mail: [info@oceanclean.de](mailto:info@oceanclean.de)  
Web: [www.oceanclean.de](http://www.oceanclean.de)

# Ocean<sup>®</sup> Clean GmbH



## MACS 130 M

Contact Ocean Clean for original,  
reliable and genuine spare parts.

# FOR OCEAN'S SAKE

### Technical Data

Size: 1860 x 980 x 2140mm (LxWxH)  
Weight: 1850kg  
Power: <30kW, 400V/50Hz, 41A  
Water: Inlet ½" (drinking water, min. 4.5bar)  
Outlet 2"  
Operating Temperature: 5-40°C  
Degree of protection: IP54

To be installed in garbage treatment room.  
Unit including all internal piping and wiring, ready for  
installation. Retrofit versions available. Different  
voltages available.

PLC supports different  
programs:

- Shredding only
- Dehydration
- Sterilization
- Internal cleaning

Duration of these  
programs does vary.



Two-Hand-Operation for  
maximum safety.  
Automatic discharge of  
treated waste into plastic  
bag for easy and safe  
storage.



Ocean Clean - A Member of Kloska Group & Neuenhauser Group

**neuenhauser**

Ocean Clean GmbH  
Zum Kühlhaus 5  
18069 Rostock  
Germany

Phone: +49 381 811 29 30  
Fax: +49 381 811 29 39  
E-Mail: [info@oceanclean.de](mailto:info@oceanclean.de)  
Web: [www.oceanclean.de](http://www.oceanclean.de)

**Ocean<sup>®</sup>  
Clean GmbH**





# MACS 130 M

Contact Ocean Clean for original, reliable and genuine spare parts.

## FOR OCEAN'S SAKE

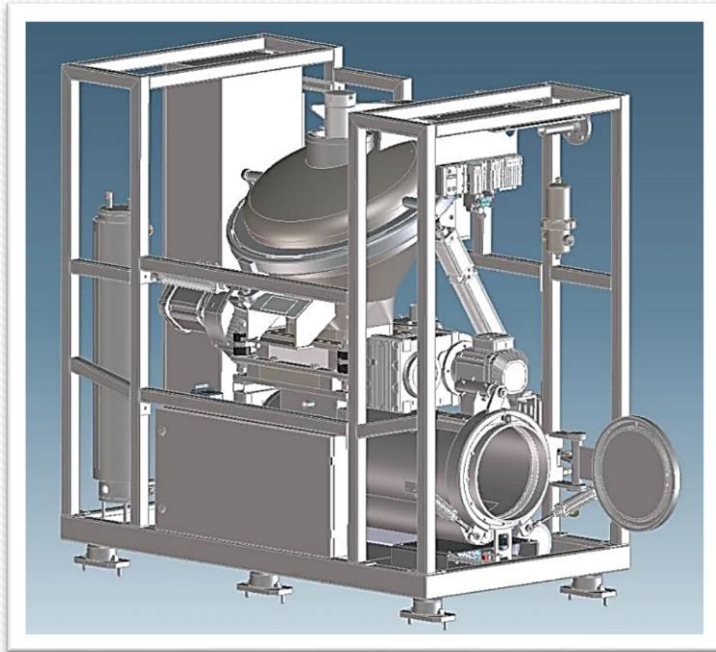

Technical drawings showing dimensions: 1950 (width), 1885 (height), 7915 (depth), 495 (height), 365 (width), 735 (height), 430 (width), 1590 (height), 1125 (height).

MuTschub 130

|   |                                 |   |             |
|---|---------------------------------|---|-------------|
| Bestellung an nachfolgender<br>spezifischer Packung | Neuenhauser                     | Ausgabe mit<br>den Dimensionen:<br>mit 1100 x<br>200 x 1700 | A3          |
| Ocean<br>Name 1                                     | Service<br>MACS130M Verkleidung | Maße<br>1125<br>1950  | 1:20<br>1:1 |
| BT Material: Ocean Name                             | Bestellung<br>MACS130M-01-07    |   |             |
| Zeichn. Nr. 130-01-07                               |                                 |   |             |
| Zeichn. Nr. 130-01-07                               |                                 |   |             |
| Zeichn. Nr. 130-01-07                               |                                 |   |             |

Pictures for illustration only.  
Subject to technical changes and misprints.



Ocean Clean - A Member of Kloska Group & Neuenhauser Group



Ocean Clean GmbH  
Zum Kühlhaus 5  
18069 Rostock  
Germany

Phone: +49 381 811 29 30  
Fax: +49 381 811 29 39  
E-Mail: info@oceanclean.de  
Web: www.oceanclean.de

